

DynaTorque Inc.

D-Stop™ Installation & Operation Procedures

Design:

All DynaTorque operators & accessories have been designed to transmit the rated output torque of the operator plus a safety factor. When designing mounting kits, torque transmission devices, or specifying mounting hardware, the unit torque rating should be considered. DynaTorque recommends using minimum grade 5 bolts with lock washers for mounting D-Stops to valve actuator mounting flanges or adaptation kits. D-Stops should not be installed in areas or process applications where they will be subjected to high temperatures (above 350 degrees F), low temperatures (below -20 degrees F), corrosive atmospheres, or high pressures without prior knowledge and written approval by DynaTorque or unless originally designed for that purpose. Doing so will void warranty. Please contact the factory (see below) with questions or consult product specification sheets.

Installation Steps:

The DynaTorque D-Stop device provides a methodology to partially-stroke-test or “exercise” double acting or spring return automated valve assemblies. Each D-Stop comes complete with a drive coupling, which if not already modified, can be removed and machined to fit the valve actuator and valve stem coupling requirements. Before assembly is begun please insure that the drive coupling has been machined correctly.

The following steps should be taken to install a DynaTorque D-Stop. DynaTorque recommends mounting the D-Stop while the valve and actuator are on a test stand and in the failed position.

1. Check to insure that the valve, actuator, and D-Stop output are in the failed position. (Full clockwise or counter-clockwise).
2. DynaTorque recommends a watertight seal be established between the bottom of the D-Stop and the valve bonnet or mounting pad at time of installation. Apply a liberal amount of a liquid gasket material (DynaTorque recommends Loctite 51580) on the valve bonnet or mounting pad prior to D-Stop installation. Make sure to surround the mounting holes to assure a complete seal.
3. With the drive coupling removed from the D-Stop, place the D-Stop on the valve assembly and loosely bolt into place.
Note: Mounting holes on some D-Stops break into the housing cavity creating a grease leak path. The use of Teflon tape is recommended for all valve side bolt installations.
4. Before reinstalling the drive coupling, liberally grease the outside of the drive coupling and the D-Stop bore with Lithium/Aluminum or Polyurea Complex grade 1 1/2 or 2. This will reduce the possibility of corrosion between the two components.
5. Reinstall the drive coupling making sure the end of the drive coupling is configured to fit the valve stem and is correctly aligned. The Coupling Key on the external circumference of the drive coupling must align with the keyway in the D-Stop drive cam.

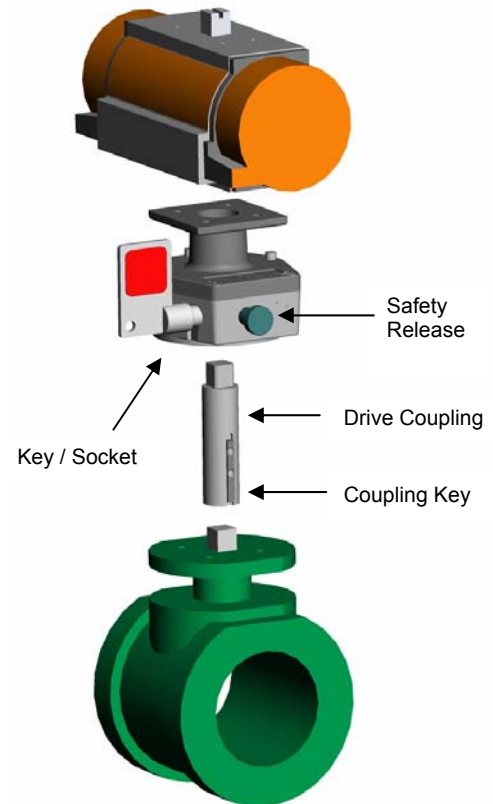

6. Tighten mounting bolts connecting to the D-Stop to the valve. Torque the bolts per industrial standards.
7. Steps should also be taken to provide a watertight seal between the top flange of the D-Stop and the bottom of the actuator. This step can be accomplished by applying a liberal amount of a liquid gasket material on the top flange of the D-Stop making sure to surround the mounting holes, as in number 2, above
8. The opposite end (or “top”) of the drive coupling should be configured to match the valve actuator torque output drive. Align the valve actuator drive with the override drive coupling and lower the actuator into place on the top D-Stop mounting flange.
9. Bolt the valve actuator into place. Torque the bolts per industrial standards.
10. Before operating the valve actuator, make sure that the D-Stop is in the disengaged position and that the D-Stop key is not in the device.
11. Cycle the valve actuator to assure all connections are correct and operation is smooth.

Trouble Shooting:

1. If the assembly does not cycle, check power connections to the valve actuator to assure it is functional. If the valve actuator is operational go to step 2.
2. Loosen bolts connecting D-Stop to both valve and valve actuator sufficiently to allow components to be moved slightly. Make sure all components of the assembly are centered and re-tighten bolts.
3. If the D-Stop is determined to be the cause of the assembly not operating, call your authorized DynaTorque representative or distributor (<http://www.dynatorque.com/distmap.html>), or call DynaTorque Inc directly at 231-739-1431.

Operation:

Warning! The D-Stop is designed to operate at specific torque loads and speeds of operation. Under no circumstance is the D-Stop maximum torque rating or stroke speed to be exceeded. Note that D-Stop torque rating and actuator torque rating may be different! Contact the factory if there is any doubt.

1. Remove the D-Stop key socket protector.
2. Insert engagement key into the D-Stop key socket. Make sure that the key is fully engaged.
3. Disengage the spring-loaded safety release by pulling. While holding the safety release in the disengaged position, turn the D-Stop engagement key a few degrees counter-clockwise and then discontinue pulling the safety release. Continue rotating the key a full 90 degrees until the safety release knob visually moves inward. The D-Stop is now engaged. For D500DS and above, the rotational force necessary to rotate the key is excessive. The engagement key assist handle has been provided for ease of operation. The “assist handle” **can be** rotate when the engagement key is not inserted, but will not rotate the engagement cam inside the D-Stop. **Do not use the key to rotate the engagement cam on D500DS and larger. Only use the engagement key assist handle.**

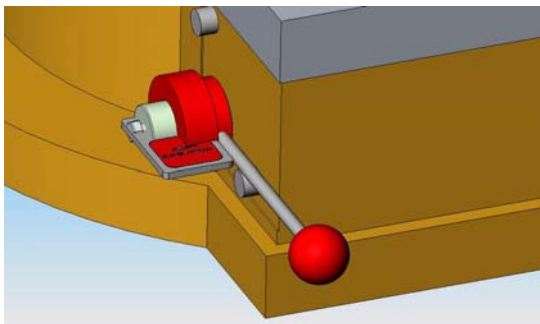

Engagement Key Assist Handle



4. Cycle Valve Actuator to the test position.
5. Verify that valve assembly package has successfully stroked to the D-Stop set point.
6. Return the valve actuator to its original position.
7. Turn D-Stop engagement key 90 degrees clock-wise to the disengaged position. Once again make sure that the safety release knob visually moves inward to ensure that the engagement cam is locked in its disengaged position.
 - For D500DS and above, the safety release must be pulled and the engagement key assist handle rotated clockwise a few degrees. Discontinue pulling the safety release knob and continue rotating the handle to the disengaged position making sure that the safety release knob visually moves inward.

Assure this step is complete by attempting to rotate the key counterclockwise without pulling the safety release knob. The key should not rotate. If it does rotate, consult the factory immediately.

8. Remove engagement key.

(Note: It is imperative that step number 7 be completed after every partial stroke test. Failure to complete step 7 could render the valve inoperable.

9. Replace key socket protector.

Maintenance:

1. Make sure D-Stops are stored in a clean, non-corrosive, dry location prior to assembly.
2. When installed in applications within design parameters, D-Stops do not require periodic maintenance.
3. Always make sure to return the D-Stop key socket cover to the key socket after partial stroke testing has been completed. This cover has been designed to keep the key socket free of foreign materials that could render the D-Stop inoperable.

Notes:

1. D-Stops shipped after January 1, 2002 are factory sealed and require no routine maintenance. Removing the D-Stop cover from the housing will void the warranty and may render the device inoperable. Prior to **ANY MAINTENANCE**, always consult the factory directly using the contact information provided below.
2. For additional information about the DynaTorque D-Stop please visit our website at www.DynaTorque.com/dstop.

Please Note:

When assembling DynaTorque products to a valve or to an automated valve package, standard engineering practices must be utilized to assure proper mounting orientation, configuration, and distribution of weights and forces. Failure to do so could cause product damage and/or malfunction, **and void warranty consideration**. If there are any questions please contact the factory at info@dynatorque.com.

D-Stop is a trademark of DynaTorque, Inc. Patent
#6935610 © DynaTorque, Inc. All Rights Reserved

Email: info@dynatorque.com
Ph: 231-788-7025
Fax: 231-788-7030