

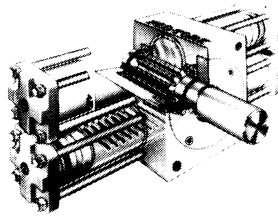

FLO-TORK®

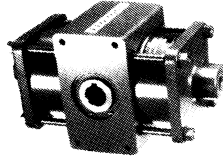

FS 106
May 2004

MAINTENANCE INSTRUCTIONS

SERVICE

Hydraulic Rotary Actuators

MODELS 75,000 THROUGH 600,000

FLO-TORK, INC.
1701 N. MAIN ST. P.O. BOX 68, ORRVILLE, OHIO 44667-0068

PHONE 330-682-0010

FAX 330-683-6857

MAINTENANCE INSTRUCTIONS

MAXIMUM OPERATING PRESSURE – 3000 psi NON-SHOCK

KEY CONSIDERATION IN THE DISASSEMBLY OF THE UNIT IS DETERMINING THE PINION SHAFT KEYWAY RELATIONSHIP TO THE RACK POSITION TO MAINTAIN PROPER TIMING AT RE-ASSEMBLY.

NOTE: STANDARD UNITS ARE TIMED WITH THE PINION SHAFT KEYWAY AT 12 O'CLOCK WHEN LOOKING AT THE BEARING CAP SIDE AS SHOWN ON THE ENCLOSED TYPICAL DRAWING.

GENERAL

FLO-TORK ROTARY ACTUATORS REQUIRE CLEAN, FILTERED HYDRAULIC OIL FOR SATISFACTORY OPERATION THE SAME AS ANY OTHER HYDRAULIC COMPONENT. THE STANDARD BUNA-N SEALS ARE DESIGNED FOR PETROLEUM BASE FLUIDS. DURING RE-ASSEMBLY, TORQUE ALL BOLTS IN ACCORDANCE WITH ENCLOSED TORQUE TABLE.

DISASSEMBLY

- 1) Place unit on bottom (MS2) with pinion shaft in horizontal position. NOTE: Place unit over a pan or tub when doing this as the unit is filled with gear lubricating oil which will drain from the housing when the cylinder tube(s) are removed.
- 2) Remove the cylinder head tie bolts/tie rods..
- 3) Remove the cylinder heads.
- 4) Remove the cylinder tubes. Gear case lubrication will drain from the housing.
- 5) Determine that the rack is at mid-point of travel (equal amounts of rack extended on each side of housing). For standard timed units the pinion keyway will be at the 12 o'clock position. For non-standard timed units note and record pinion shaft location for re-assembly.
- 6) Remove the socket head cap screws from the shaft side (MS1) bearing cap. Remove bearing cap. Remove and keep any shims used between housing and bearing cap. These shims will be reused at re-assembly.
- 7) On dual rack units, use blocks or jacks to support the upper rack after the pinion is removed.
- 8) Pull pinion and front bearing from the housing.
- 9) Remove top rack bearing (for dual rack units).
- 10) Remove piston/rack assembly(s) and lower rack bearing.
- 11) Remove pistons from rack(s).
- 12) Remove the back pinion bearing.
- 13) Remove all O-rings and seals.
- 14) Thoroughly clean and inspect all parts for wear or damage. Replace with new parts as required. Lubricate with light oil before re-assembly.

RE-ASSEMBLY

- 1) Re-assembly will be accomplished with less difficulty if the housing is placed on its bottom (MS2). In the case of single rack units, the rack opening should be on the bottom.
- 2) Install new O-rings, back-up rings and seals in their proper grooves (see drawing).
- 3) Install cylinder tube(s) on one side of housing.
- 4) Install cylinder head(s) and tie bolts. Snug bolts but do not torque until re-assembly is complete.

- 5) Install back pinion bearing race.
- 6) Attach one piston to the rack(s) with piston bolt. Use Blue Loctite No. 242 on bolts and torque to specified torque. Install piston plug or cushion nose at this time. Do not use Loctite.
- 7) Slide bottom rack (with piston attached) thru housing into the cylinder tube. Install the bottom rack bearing at the same time.
- 8) On dual rack units, be sure to install only the bottom rack.
- 9) Install back pinion bearing. Be sure to do this before installing the top rack in dual rack units. Install pinion O-ring in groove behind back pinion bearing.
- 10) Install top rack (in a dual rack units) thru housing into the cylinder tube. Do not install top rack bearing at this time.
- 11) Adjust rack(s) to mid-point of travel (equal amounts of rack extended on each side of housing).
- 12) Install pinion with the shaft keyway location as noted during disassembly. (Standard unit timing will have keyway at 12 o'clock location when looking at the bearing cap face.) Be sure to seat pinion shaft in back pinion bearing.
- 13) Install top rack bearing (in a dual rack units).
- 14) Install remaining piston(s); use Blue Loctite No. 242 on bolts and torque to specified torque. Install piston plug or cushion nose at this time. Do not use Loctite.
- 15) Install remaining cylinder tube(s), cylinder head(s) and tie bolts. Snug bolts but do not torque.
- 16) Lay unit down on back (MS3) and fill housing with ISO Grade 68 gear oil or equivalent up to the top of the rack teeth.
- 17) Torque cylinder head tie bolts to specified torque. Torque bolts evenly by applying force alternately on opposite corners of the heads.
- 18) Install front pinion bearing.
- 19) Replace shims that were removed during disassembly.
- 20) Install bearing cap and socket head cap screws, use Blue Loctite No. 242 on cap screws.
- 21) Torque socket head cap screws evenly to specified torques.
- 22) Clean/flush the hydraulic piping.
- 23) Connect the hydraulic piping to the cylinder ports.
- 24) Bleeding air from the ports and supply lines will improve the performance of the actuator. In order to remove the maximum amount of air during installation, apply minimum pressure (not to exceed 50 psi) to the port and crack open the air bleed fitting or port fitting. As the line and port fill with fluid and a steady stream of fluid starts to come out around the fitting, tighten the fitting. In order to remove all the air from the actuator, it will be necessary to cycle the actuator to the end of stroke in each direction. Repeat the air bleeding process for each cylinder tube (not exceeding the 50 psi pressure) when the actuator is at the end of stroke in each direction.

STANDARD MODELS 75,000 THRU 600,000
 MODEL 300,000 IS SHOWN

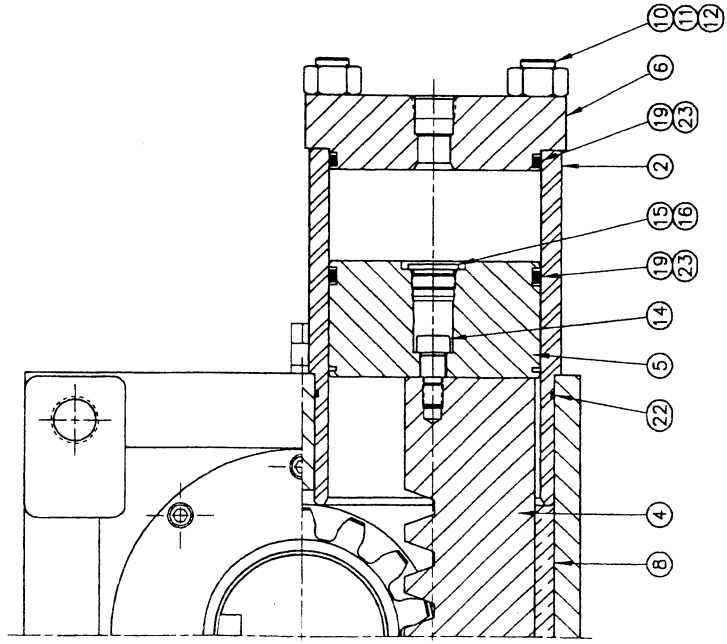
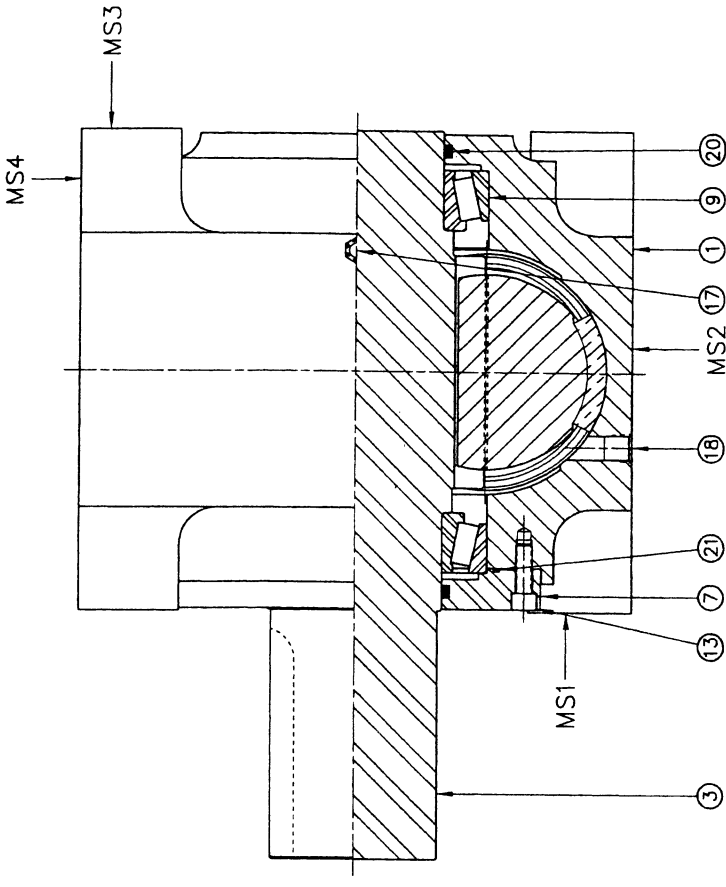

ITEM	PART NAME	ITEM	PART NAME
1	HOUSING	13	BOLT - BEARING CAP
2	CYLINDER TUBE	14	BOLT - PISTON
3	PINION	15	PLUG - PISTON
4	RACK	16	O-RING - PISTON PLUG
5	PISTON	17	RELIEF VALVE
6	END CAP	18	PIPE PLUG - DRAIN AND FILL
7	BEARING CAP	19	O-RING - PISTON AND END CAP
8	RACK BEARING	20	O-RING - PINION
9	PINION BEARING	21	O-RING - BEARING CAP
10	TIE ROD	22	O-RING - CYLINDER TUBE
11	LOCKWASHER	23	BACK-UP RING - PISTON AND END CAP
12	NUT - TIE ROD		

TORQUE TABLE		
ITEM	PART NAME	TORQUE
12	NUT - TIE ROD	75/150000 300/600000
13	BOLT - BEARING CAP	70 FT-LBS 400 FT-LBS
14	BOLT - PISTON	40 FT-LBS 70 FT-LBS
		30 FT-LBS 30 FT-LBS

0° TO 5° INTERNAL ADJUSTABLE STOPS

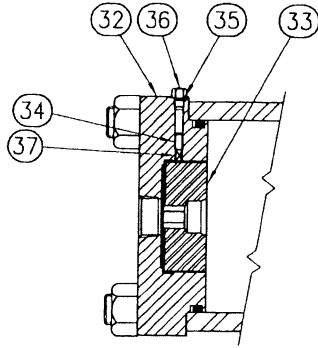

ITEM NO.	PART NAME	QUANTITY
32	CYLINDER HEAD	1
33	0° TO 5° INTERNAL ADJ. STOP	1
34	SET SCREW - ADJ. STOP	1
35	O-RING - ADJ. PLUG	1
36	PLUG - ADJUSTER	1
37	NYLON PELLET	1

DISASSEMBLY – 0° TO 5° INTERNAL ADJUSTABLE STOPS

1. Remove adjuster plug and O-ring.
2. Loosen the adjustable stop-set screw.
3. With cylinder head removed from cylinder tube, the adjuster can be removed by screwing out towards the inside of the cylinder head with a hex wrench.
4. Remove nylon pellet and inspect for wear or damage. Replace with new pellet if required.

RE-ASSEMBLY - 0° TO 5° INTERNAL ADJUSTABLE STOPS

NOTE: MUST BE RE-ASSEMBLED BEFORE CYLINDER HEAD IS MOUNTED TO CYLINDER TUBE.

1. Screw adjuster into cylinder head from inside of cylinder head face. Screw adjuster in until flush or below the surface of the cylinder head so that rotation can be adjusted at test.
2. Install nylon pellet and set screw but do not tighten until adjustment is set.
3. Adjust rotation at test. Turning adjuster clockwise reduces rotation, counter-clockwise increases rotation.
4. When adjustment is complete tighten set screw to lock position.
5. Install adjuster plug and O-ring.

NOTE: ADJUSTMENTS SHOULD NOT BE MADE WHILE UNIT IS UNDER PRESSURE. FOR DUAL RACK UNITS, BOTH ADJUSTERS AT EACH END OF STROKE MUST BE SET EQUALLY SO THAT END OF STROKE LOAD IS EQUALLY ABSORBED BY (2) CYLINDER HEADS.

CAUTION: Maximum adjustment is limited to only (3) complete turns of adjuster from fully retracted position. Fully retracted position is when adjuster is flush with inside face of end cap.

ALWAYS USE SERIAL NUMBERS AND MODEL NUMBERS WHEN ORDERING PARTS.

0° TO 30° EXTERNAL ADJUSTABLE STOPS

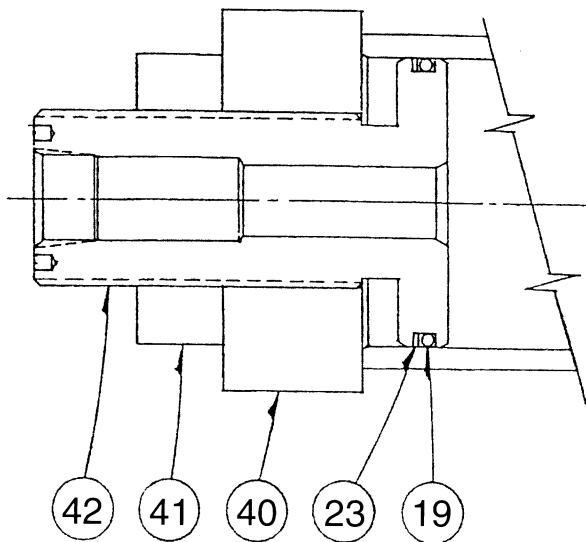

ITEM NO.	PART NAME	QUANTITY
23	BACK UP RING, CYL. HD.	1
19	O-RING, CYL. HD.	1
40	EXTERNAL ADJUSTOR CYL. HD.	1
41	JAM NUT	1
42	EXT. ADJ.-FIXED CUSHION	1

DISASSEMBLY – 0° TO 30° EXTERNAL ADJUSTABLE STOPS

NOTE: CYLINDER HEAD MUST BE REMOVED FROM THE CYLINDER TUBE BEFORE DISASSEMBLY.

1. Remove jam nut.
2. Screw adjuster out of the cylinder head. Remove O-ring and back-up ring from adjuster head.
3. Thoroughly clean and inspect all parts for wear or damage. Replace with new parts as required.

RE-ASSEMBLY - 0° TO 30° EXTERNAL ADJUSTABLE STOPS

NOTE: MUST BE RE-ASSEMBLED BEFORE CYLINDER HEAD IS MOUNTED TO CYLINDER TUBE.

1. Install new back-up ring and O-ring on adjuster head making sure the flat of the back-up ring is on the cylinder head side of the seal groove and the curved side is toward the O-ring and cylinder tube side. Make sure the O-ring is installed in the curved portion of the back-up ring.
2. Screw adjuster into the cylinder head from inside of the cylinder head. Screw adjuster all the way in so that rotation can be adjusted at test.
3. Adjust rotation at test. Turning adjuster clockwise reduces rotation, counter-clockwise increases rotation.
4. Tighten jam nut.

NOTE: ADJUSTMENT SHOULD NOT BE DONE WHILE UNIT IS UNDER PRESSURE. FOR DUAL RACK UNITS, BOTH ADJUSTORS AT EACH END OF STROKE MUST BE SET EQUALLY SO THAT END OF STROKE LOAD IS EQUALLY ABSORBED BY (2) CYLINDER HEADS.

CUSHION DETAILS

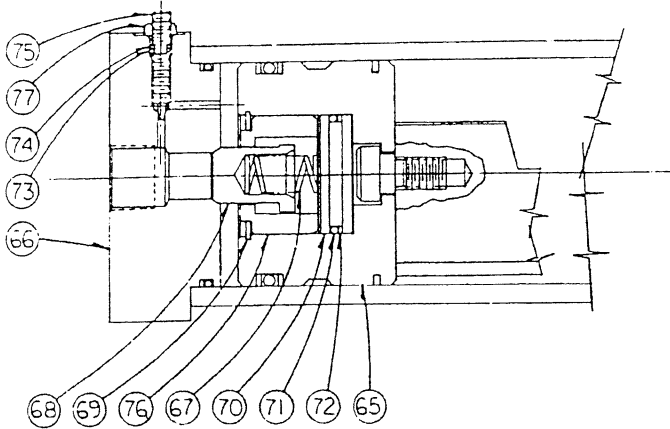

PART NO.	PART NAME	QUANTITY
65	CUSHION PISTON	1
66	CUSHION CYL. HD.-ADJUSTABLE	1
67	COMPRESSION SPRING	1
68	CUSHION CHECK	1
69	RETAINING RING	1
70	CUSHION PLUG	1
71	O-RING-CUSHION PLUG	1
72	BACK-UP RING-CUSHION PLUG	1
73	O-RING-CUSHION NEEDLE	1
74	BACK-UP RING-CUSHION NEEDLE	1
75	CUSHION NEEDLE	1
76	CUSHION CHECK RETAINER	1
77	JAM NUT	1

DISASSEMBLY - ADJUSTABLE CUSHIONS

DO NOT REMOVE CUSHION NEEDLE WHILE UNIT IS UNDER PRESSURE.

1. Remove cushion needle jam nut & cushion needle from cylinder head.
2. Remove O-ring & back-up ring. Replace with new parts during re-assembly.
3. Remove cylinder head.
4. Remove cushion check retaining ring from piston.
5. Remove cushion check retainer, cushion check, compression spring and cushion plug from piston.
6. Remove O-ring and back-up ring. Replace with new parts during re-assembly.
7. Thoroughly clean and inspect all parts for wear or damage, replace parts as required.

RE-ASSEMBLY - ADJUSTABLE CUSHIONS

1. Install new back-up ring on cushion plug. Make sure that the curved side faces toward the compression spring.
2. Install new O-ring on cushion plug, making sure the O-ring fits into the curved side of the back-up ring.
3. Install cushion plug in piston.
4. Install compression spring, cushion check and cushion check retainer in piston.
5. Secure in place with the cushion check retaining ring.
6. Install new back-up ring on cushion needle making sure that the curved side faces toward the needle end.
7. Install new O-ring on the cushion needle making sure it is on top of the back-up ring and the O-ring fits into the curved side of the back-up ring.
8. Insert the cushion needle in the cylinder head being careful not to damage the seals. Tighten as far as possible, then loosen 1 1/2 turns. Install jam nut.
9. Install cylinder head.
10. Adjust cushion at test.

CUSHION ADJUSTMENT

NOTE: DO NOT ADJUST WHILE UNIT IS UNDER PRESSURE.

1. The control needles of the cushion are installed and locked 1 1/2 turns from closed when assembled at the factory to prevent premature damaging of the actuator during installation and start-up.
2. Increase cushioning - loosen cushion needle jam nut 1/2 to 1 turn. Turn cushion needle clockwise 1/8 turn. Lock jam nut and check cushion action.

NOTE: NEVER COMPLETELY CLOSE CUSHION NEEDLES.

3. Decrease cushioning - loosen cushion needle jam nut 1/2 to 1 turn. Turn cushion needle counter-clockwise 1/8 turn. Lock jam nut and check cushion action.

NOTE: CAUTION IS TO BE TAKEN WHEN ADJUSTING THE CUSHION NEEDLE TO INSURE THAT IT HAS ADEQUATE THREAD ENGAGEMENT and WILL NOT BLOW OUT OF HOLE.

4. Continue adjusting cushion needles in the above described manner until the desired cushioning effect is obtained.

SEAL LEAKAGE

FLO-TORK ROTARY ACTUATORS MAY BE CHECKED FOR PISTON SEAL LEAKAGE AS FOLLOWS:

1. SET UP ACTUATOR WITH RELIEF FITTING UP.
2. PRESSURIZE CYLINDER PORTS INDIVIDUALLY
3. IF OIL FLOWS FROM RELIEF PORT AFTER PISTON HAS COMPLETED ITS TRAVEL AND IS HELD FOR 3 MINUTES UNDER PRESSURE, ALL PISTON SEALS SHOULD BE REPLACED.

FOR FURTHER MAINTENANCE INFORMATION CONTACT YOUR NEAREST FLO-TORK REPRESENTATIVE OR
FLO-TORK, INC., ORRVILLE, OHIO

ALWAYS USE SERIAL NUMBERS AND MODEL NUMBERS WHEN ORDERING PARTS



FLO-TORK, INC.

1701 N. MAIN STREET P.O. BOX 68 ORRVILLE, OHIO 44667-0068

TEL: 330-682-0010

FAX: 330-683-6857