

NO	PART NAME	MATERIAL	Q'TY	REMARK
1	BODY	AC2B	1	AC4C
2	TOP COVER	AC2B	1	AC4C
3	HANDLE	AC2B	1	
4	LEVER	SM45C	1	SUM24L
5	BASE	GC250	1	
6	DRIVE BUSHING	SM45C	1	
7	INDICATOR	PC	1	
8	CONDUIT ENTRIES		2	PF3/4"
9	STOPPER BOLTS	SUS316	2	M14*60
10				
11				
12				

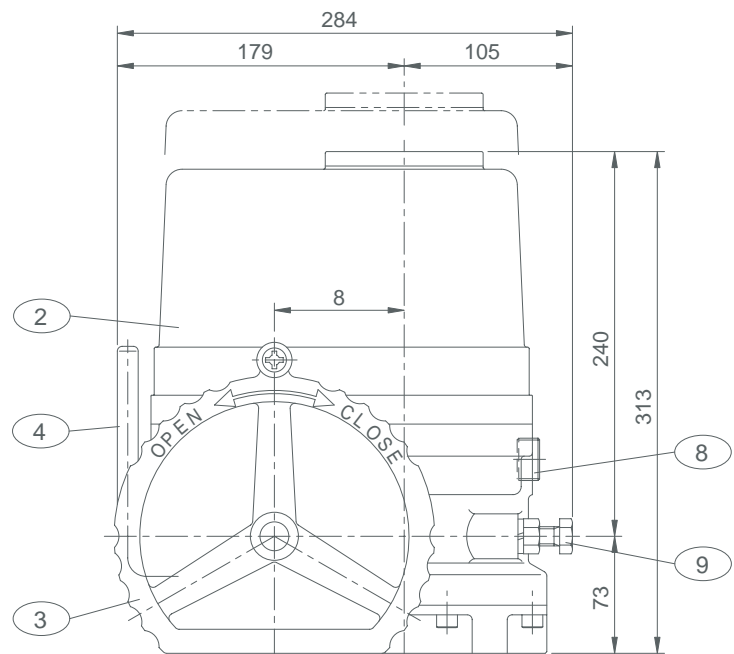
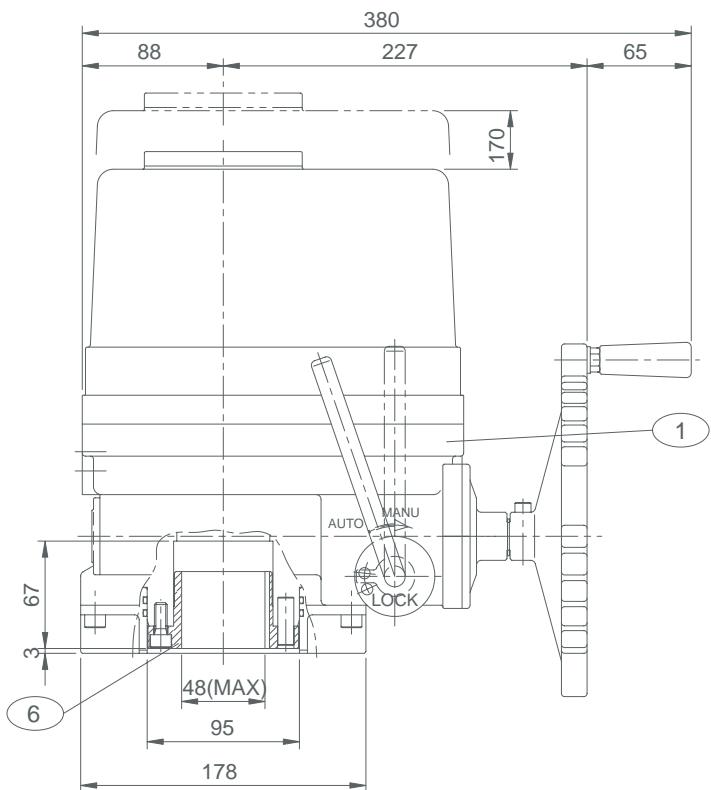

ITQ1100	
ITQ0800	1
APPL.FILE	

CONTROLS Ltd. http://www.i-tork.com				MATERIAL		PROJ.	
DRAWN		DESIGN		DIMENSION		HEAT TREAT.	
C.J. CHU		C.J. CHU		mm		SURF. TRET.	
CHECKED		APPROVER		ISSU. DEPT.		DATE	
				ITCDR		'03.10.15	
SCALE		DATE		SIZE		1	
N/S		'03.10.15		A2		1	
PART NAME				DWG NO			
ITQ0800/1100 LAYOUT				ITQ0800-50010-A			